

CROSS SECTION OF ELECTRON ANTINEUTRINO INTERACTION WITH ^{40}Ar AND ^{84}Kr AND ITS RELEVANCE TO GEONEUTRINO DETECTION

Akmal Ferdiyan*, Urip Nurwijayanto Prabowo

Department of Physics, Faculty of Mathematics and Science, Universitas Jenderal Soedirman, Jl. Dr. Soeparno Utara 61, Purwokerto 53122

Received: 3rd November 2020 ; Revised: 29th December 2020 ; Accepted: 28th January 2021

ABSTRACT

Neutrino can carry information from places that cannot be reached by the usual detection mechanism because it has a very weak interaction with matter. This can be utilized to study the heat flow process inside the earth by using information carried by geoneutrino (electron antineutrino). In this sense, it is important to know the characteristics of neutrino interaction with materials. In this study, the cross-section calculation of the electron antineutrino interaction with Ar-40 and Kr-84 was carried out using computational methods with the help of GENIE software. In the energy range of 0-10 MeV, the dominant interaction between the two materials is the interaction of QES NC and MEC types with an energy threshold of 5,09 MeV. Both Ar-40 and Kr-84 cannot be used as a scintillator material for geoneutrino detection because in the energy range 0-4,4 MeV the cross-sectional value of the CC interaction $\bar{\nu}_e + p \rightarrow n + e^+$ is 0.

Keywords: Geoneutrino; Cross-section; Computational physics

Introduction

Neutrinos have long been known in the world of physics through the beta decay process $n \rightarrow \bar{\nu}_e + p + e^-$, as can be seen in Figure 1. The beta-decay process occurs when radioactive materials are present, such as ^{238}U and ^{60}Co . Neutrino interactions with another matter are very weak, so from the time neutrino was hypothesized by Pauli in 1930, the neutrino was first detected by Reines and Cowan only in 1956. The weak interaction of neutrino makes its detection to be difficult to do, but it also opens up new opportunities for the utilization of information carried by a neutrino. Since it can go through matter almost without interacting at all, it can penetrate through matters which are not penetrable by photon or electron. This opens up the possibility of using neutrino data to determine the characteristics of the previously inaccessible region in the universe.

The characteristics of neutrino interaction with various material are being studied to

know what kind of material that is sensitive to detect neutrinos generated by a source.

The source of neutrino can be an explosion of high-energy supernovas,¹ from a nuclear reactor, and from heat-producing elements that reside in the earth.²⁻⁴ The latter is heat-producing elements (^{238}U , ^{232}Th , and ^{40}K) in the earth that produces electron antineutrino known by the name of geoneutrino. Currently, research on geoneutrino is being developed because of the potential for information that can be obtained from it. Geoneutrino can go through the layers of the earth almost unhindered. From the geoneutrino data, there is potential for knowing the composition of the interior of the earth and the heat flow within the earth.⁵ Understanding the heat flow process and the mechanism is very important to understand geological processes, because the energy from geological processes like volcanology, plate movements, and earthquakes partly comes from the heat flowing inside the earth.⁶

*Corresponding author.

E-Mail: aferdiyan@unsoed.ac.id

Neutrino interactions with matter, in general, involve calculation which is quite complicated because of the many factors/variables that must be considered. For example, the cross-section of neutrino interaction for the inverse beta decay (IBD) process ($\bar{\nu}_e + p \rightarrow n + e^+$) which is used to detect geoneutrino, in general, is given by the following equation:

$$\sigma_n(E_\nu) \cong \frac{2\pi^2}{m_e^5 f \tau_n} E_e p_e \quad (1)$$

with σ_n is the cross-section of neutrino interactions as a function of neutrino energies. E_e , p_e , m_e respectively are energy, momentum, and electron mass.

f is the phase-space factor of the neutron decay, and τ_n is the lifetime of a neutron. The energy of the electron is the result related to interactions of the energy of interacting neutrinos. The diagram for IBD is given in Figure 2. This interaction can be used to distinguish antineutrino interaction since it has the signature of two-photon flash occurred separated by specific time interval. One photon flash is produced by thermal neutron interaction with scintillator material and the second flash (2 photons) is produced by the annihilation process of a positron (from IBD) with the nearby electron.

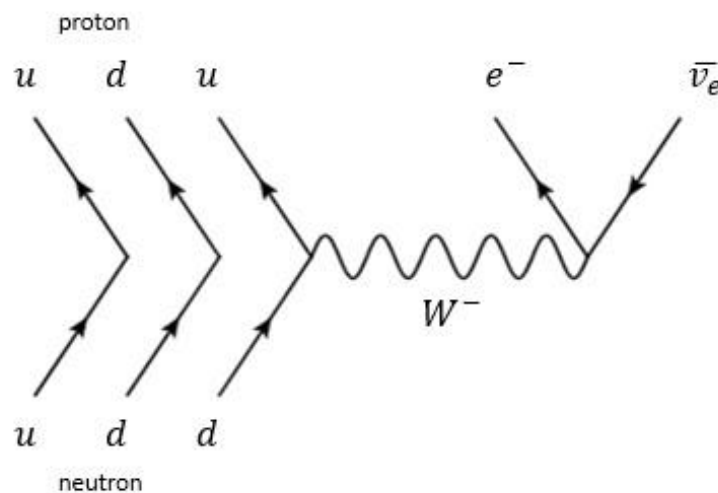

Figure 1. Beta-decay process in which antineutrino electrons are produced.

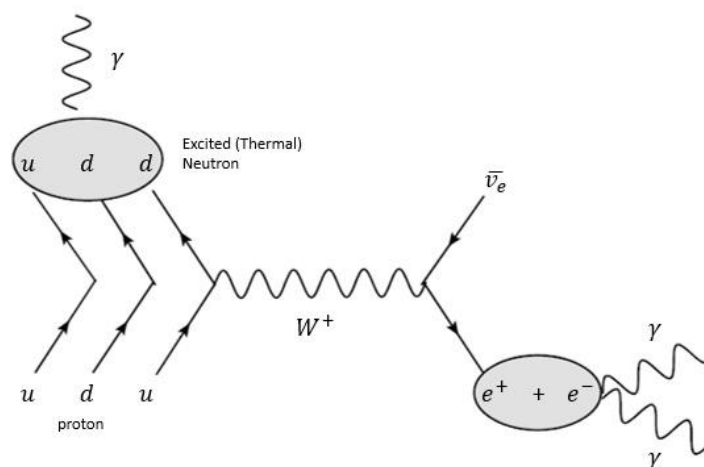

Figure 2. Inverse beta decay $\bar{\nu}_e + p \rightarrow n + e^+$ used in detecting geoneutrinos.

More detailed calculations require corrections related to the neutrino oscillation

process.⁷ The detection of geoneutrino is reported by KamLAND and Borexino

experiments.^{8,9} Both experiments use liquid scintillator material to detect geoneutrino interaction. Liquid scintillator needs to be purified before it can be used to detect geoneutrino, otherwise, it will interfere with the detection process.

Currently, there are tools such as computing software for calculating cross-section of interactions and determining the expected interactions of the neutrino when passing through a material. The initial data are energy and the flux of neutrino, combined with the physical properties of the target material. These inputs will give the interaction processes between neutrinos and matter. One of the interactive computing software for neutrino is GENIE (Generate Events for Neutrino Interaction Experiments) which uses the Monte Carlo method to simulate a neutrino interaction with material.¹⁰

Methods

This research was conducted using computational methods. The cross-section of neutrino interaction is computed by using GENIE. The material used as the detector for the neutrino detection process will be selected

according to some of the following properties: it has chemical stability, good optical properties (good transparency), and can be used in large quantities (the probability of neutrino interactions depends on the number of protons on the target).¹¹ In this study, the materials are chosen from the noble gas group (Argon and Krypton). The input from the material, which are the ⁴⁰Ar and ⁸⁴Kr isotopes, can be used as an input for GENIE. GENIE input is using the naming code according to the standards in the Particle Data Group. Antineutrino electron $\bar{\nu}_e$ is the incoming particle, and ⁴⁰Ar and ⁸⁴Kr isotopes are the target. The energy of the incoming antineutrino is set between 0-10 MeV, since the range of energy of geoneutrinos are between 0-4,4 MeV.⁷

Result and Discussion

A. Cross-section of ⁴⁰Ar

The result for the cross-section of antineutrino electron interaction with ⁴⁰Ar gives the information for the type of processes that occurred for this particular interaction. The details of this interaction can be seen in Figure 3.

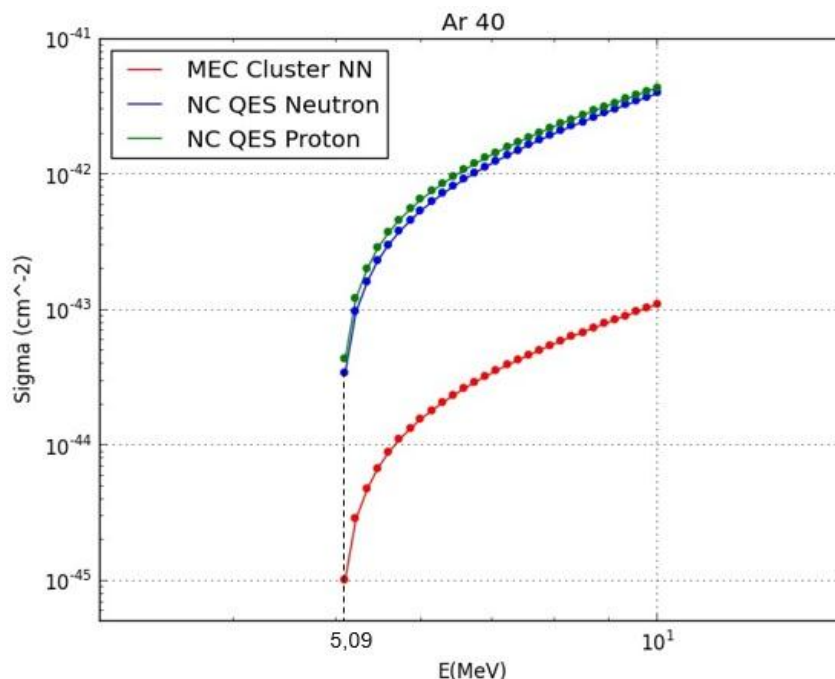

Figure 3. Cross-section σ (cm⁻²) of antineutrino interaction with ⁴⁰Ar in 0-10 MeV energy range.

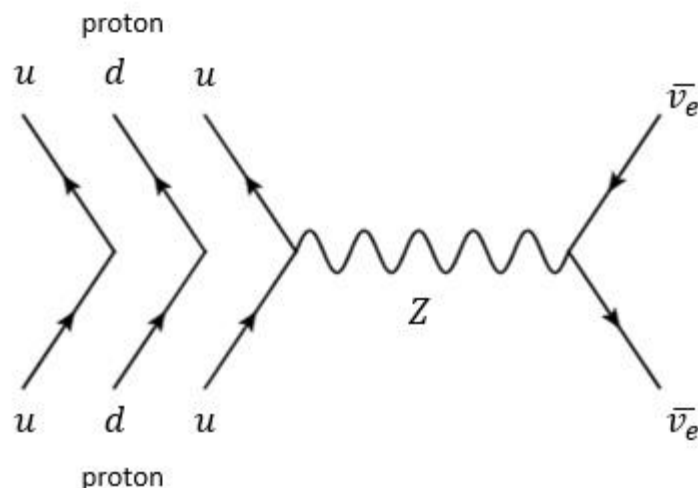

Figure 4. Neutral current interaction

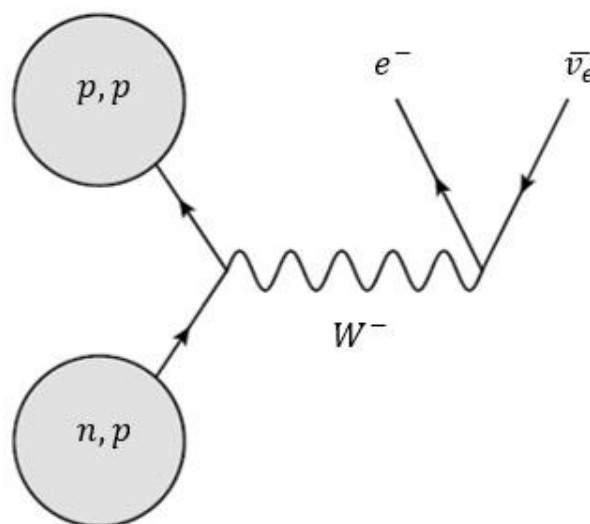

Figure 5. Mesons exchange current interaction

There are 2 dominant types of interactions, Quasi Elastic Neutral Current (NC) or QES NC and Mesons Exchange Current (MEC). The QES NC interaction is given by $\bar{\nu}N \rightarrow \bar{\nu}N$ with an exchange of neutral vector boson Z. The nucleon N is either proton or neutron. The diagram of NC interaction is given in Figure 4.

The MEC interaction is an interaction involving 2 nucleons and the result is an emission of 2 nucleons. The diagram for this interaction for the neutron and proton pair can be seen in figure 5. The nucleon interacts as a pair with incoming antineutrino.¹²

The result for cross-section value as given in Figure 3 is between $(0,34-39,78) \times 10^{-43}$

cm^{-2} . The cut-off value for both interactions is 5.09 MeV. The cross-section value for NC interaction involving a proton is higher than a neutron. The MEC interaction occurred between antineutrino with neutron-neutron pairs, which means it involves a neutral Z boson. The cross-section value for MEC interaction is much lower than NC, which means it has a lower probability to take place in the ⁴⁰Ar interaction with an antineutrino electron in the given energy range.

There is no Charged Current (CC) interaction for $\bar{\nu}_e$ and ⁴⁰Ar in the energy range of 0-10 MeV.

The interaction between antineutrino and ⁴⁰Ar has been studied extensively before,

because of its importance in solar neutrino and supernovae neutrino detection. The result of this research is in agreement with¹³ for the CC interaction for energy below 10 MeV. The further study requires a more theoretical

approach and data from the experiment which are still ongoing research.¹⁴ It is a complicated study involving the nuclear effect in nucleon and experimental techniques to achieve more sensitivity and accuracy.¹⁵

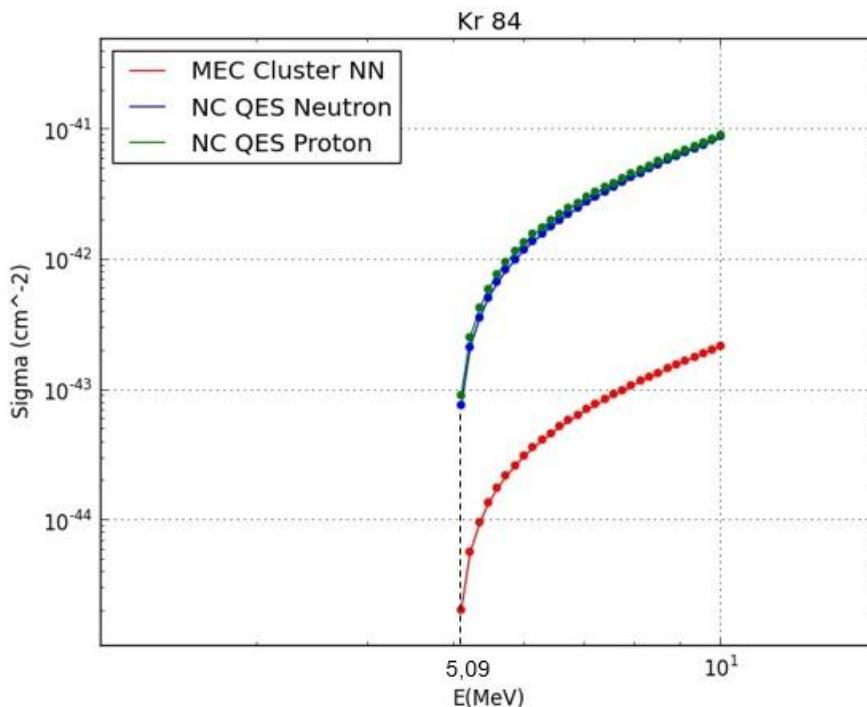

Figure 6. Cross-section σ (cm^{-2}) of antineutrino interaction with ^{84}Kr in 0-10 MeV energy range.

B. Cross-section of ^{84}Kr with antineutrino electron

The interaction between antineutrino electron and ^{84}Kr can be seen in Figure 6. The dominant types of interaction are QES NC and MEC. There are also no CC interactions found in the 0-10 MeV energy range. The cross-section value for the interaction is between $(0,02-2,19) \times 10^{-43} \text{ cm}^{-2}$. This value differs from that of ^{40}Ar since ^{40}Ar is much more sensitive to antineutrino in low energy region. The cut-off value for ^{84}Kr is also 5.09 MeV. Cross-section of NC interaction involving proton is higher than the neutron, but it almost gives the same value in the region of $E \sim 10$ MeV. The cross-section of MEC interaction also has a lower value compared to NC, so it has a lower probability to occur. Similar to the ^{40}Ar case, MEC interaction involves neutron-neutron pair with neutral Z boson as a propagator.

C. Detection of Geoneutrino

For geoneutrino detection, even though both ^{40}Ar and ^{84}Kr are very stable (no background interaction from self-decay, reduces the process of data analysis), it is shown that there is no CC interaction in the 0-10 MeV energy range. This can be seen in Figures 3 and 6. The detection of geoneutrino is done by searching for IBD ($\bar{\nu}_e + p \rightarrow n + e^+$) interaction which is a CC interaction with an exchange of charged boson W^+ (Figure 2). Given that geoneutrino energy is in between 0-4,4 MeV, it can be concluded that both materials are not suited to be used as scintillators to detect geoneutrino.

Conclusion

The interaction of antineutrino electron with ^{40}Ar and ^{84}Kr has been studied in this research by using the GENIE program in the energy region of 0-10 MeV. The results give

that for both materials the dominant type of interactions is QES NC and MEC with threshold energy of 5,09 MeV. The value of cross-section for ^{40}Ar is $(0,34-39,78) \times 10^{-43} \text{ cm}^{-2}$ and for ^{84}Kr is $(0,02-2,19) \times 10^{-43} \text{ cm}^{-2}$.

It is not recommended to use both ^{40}Ar and ^{84}Kr to detect geoneutrino which has an energy of 0-4,4 MeV, since in this energy range there is no CC interaction for both materials.

Acknowledgment

The authors would like to thank the financial support for this research from BLU Universitas Jenderal Soedirman. A.F is grateful to M. Roda for the guidance in building the GENIE system.

References

1. Aartsen MG, Hill GC, Kyriacou A, Robertson S, Wallace A, Whelan BJ, et al. Measurement of the multi-TeV neutrino interaction cross-section with IceCube using Earth absorption. *Nature*. 2017;551(7682):596–600.
2. Donini A, Palomares-Ruiz S, Salvado J. Neutrino tomography of Earth. *Nat Phys* [Internet]. 2019;15(1):37–40. Available from: <http://dx.doi.org/10.1038/s41567-018-0319-1>
3. Fiorentini G, Lissia M, Mantovani F. Geo-neutrinos and earth's interior. In: *Physics Reports*. 2007. p. 117–72.
4. Leyton M, Dye S, Monroe J. Exploring the hidden interior of the Earth with directional neutrino measurements. *Nat Commun* [Internet]. 2017;8(May):1–11. Available from: <http://dx.doi.org/10.1038/ncomms15989>
5. Agostini M, Altenmüller K, Appel S, Atroshchenko V, Bagdasarian Z, Basilico D, et al. Comprehensive geoneutrino analysis with Borexino. 2019;(September). Available from: <http://arxiv.org/abs/1909.02257>
6. Buffett BA. Taking earth temperature. *Science* (80-). 2007;315(5820):1801–2.
7. Smirnov O. Experimental aspects of geoneutrino detection: Status and perspectives. *Prog Part Nucl Phys* [Internet]. 2019;109:103712. Available from: <https://doi.org/10.1016/j.pnpnp.2019.103712>
8. Araki T, Enomoto S, Furuno K, Gando Y, Ichimura K, Ikeda H, et al. Experimental investigation of geologically produced antineutrinos with KamLAND. *Nature*. 2005;436(7050):499–503.
9. Bellini G, Benziger J, Bonetti S, Avanzini MB, Caccianiga B, Cadonati L, et al. Observation of geo-neutrinos. *Phys Lett Sect B Nucl Elem Part High-Energy Phys* [Internet]. 2010;687(4–5):299–304. Available from: <http://dx.doi.org/10.1016/j.physletb.2010.03.051>
10. Andreopoulos C, Barry C, Dytman S, Gallagher H, Golan T, Hatcher R, et al. The GENIE Neutrino Monte Carlo Generator. *Nucl Instruments Methods Phys Res* [Internet]. 2010;(A 614):87–104. Available from: <http://arxiv.org/abs/1510.05494>
11. Enomoto S, Ohtani E, Inoue K, Suzuki A. Neutrino geophysics with KamLAND and future prospects. *Earth Planet Sci Lett*. 2007;258(1–2):147–59.
12. Katori T. Meson exchange current (MEC) models in neutrino interaction generators. *AIP Conf Proc*. 2015;1663.
13. Cheoun MK, Ha E, Kajino T. Reactions on Ar40 involving solar neutrinos and neutrinos from core-collapsing supernovae. *Phys Rev C - Nucl Phys*. 2011;83(2):1–4.
14. Acciarri R, Adams C, Asaadi J, Baller B, Basque V, Bolton T, et al. First measurement of electron neutrino scattering cross section on argon. *Phys Rev D*. 2020;102(1):1–6.
15. Ankowski AM, Sobczyk JT. Argon spectral function and neutrino interactions. *Phys Rev C - Nucl Phys*. 2006;74(5):1–10.