

APPLICATION OF LM 35 TEMPERATURE SENSOR FOR SEAWATER DISTILLATION

Imam Saukani*¹, Rina Triturani²

¹*Electronic Engineering, Malang State Polytechnic
Jl. Soekarno Hatta 9 Malang, Indonesia*

²*Biology Department, Malang State University
Jl. Semarang No.5, Sumber Sari, Malang, Indonesia*

Received: 9th September 2021; Revised: 26th February 2022; Accepted: 11th March 2022

ABSTRACT

Indonesia is an archipelago, so many settlements close to the beach or sea. People living in the area are still many who lack clean water. One way to get clean water is sea water by distillation. Distillation is a liquid changes into steam and the steam is cooled back into a liquid. The process of designing and manufacturing distillation in this paper serves to make sea water into fresh water and also to stabilize the temperature during heating. Given these problems required temperature control system. Application of fuzzy logic controllers are expected to solve the problem of temperature stability in sea water distillation equipment. The sensor used is LM 35 sensors as readers seawater temperature is used as a reference to maintain a temperature in the range of 80° -100°C. Fuzzy logic rules are applied has a 9, which is obtained from the membership functions of 3 error and 3 delta error membership functions. Application of Fuzzy Logic Controller When the set point temperature of 85°C temperature response curve is obtained which has a performance controller Error Steady state = 0.35%, Max Overshoot = 0, settling time = 103 minutes, peak time = 0, rise time = 37 minutes. With the set point of 75°C -99°C then obtained a qualified water quality water temperature of 100°C is worth to drink and has a good time efficiency for distillation temperature.

Keywords: LM 35; Fuzzy Logic Controller; Distillation.

Introduction

Indonesia is an archipelagic country, so there are many settlements close to the beach or the sea. People living in the area there are still many who lack clean water.^{1,2} All this time to get clean water have to collect rainwater or buy it from another place so that the water is clean owned is limited.³ One way to get clean water is by distillation of sea water. Distillation is a change of liquid into vapor and the vapor cooled back into a liquid.^{4,5} The distillation unit operation is a method which is used to separate the components contained in the a solution or mixture and depending on the distribution of the components between the vapor phase and the water phase.⁶ Simple distillation or ordinary distillation is a chemical separation technique to separate two or more have different boiling points. A mixture can be

separated with this ordinary distillation to obtain the pure compound. The process of designing and making the distillation apparatus in this thesis works to make sea water into clean water and also to stabilize the temperature at when heating. The purpose of temperature stabilization is to determine the yield of water both at a certain temperature and efficiency in the heating process.⁷

In setting up this system, an appropriate decision is needed so that reached the desired temperature. Based on developing technology Fuzzy 2. The Logic Controller can be chosen for the solution of temperature regulation.^{8,9} Fuzzy is often referred to as a control that translates language in In everyday life, not everything can be solved mathematically.⁸

Fuzzy Logic is used to take appropriate

*Corresponding author.

E-Mail: mam_im@yahoo.com

action in order to obtain the desired result. Fuzzy logic has been successfully used to setting the temperature on the incubator that produces the system response to SP 57° can be reached in 2 minutes with a steady state error of 3 also produced a phase angle adjustment for setting the heater temperature with the system response gets the oscillation amplitude approximately 0.2°C.

Methods

In this research, there are several conceptual frameworks that will be carried

out to do research. The conceptual framework includes:

Circuit Design Stage

In general, the design and manufacture of this research system shown In this study using Fuzzy Logic fuzzy design 42 Controller as a control system.¹⁰ To clarify the control system using a Fuzzy Logic Controller can be seen in the block diagram in Figure 1. The block diagrams of the systems and controls used are intended to simplify the process of tool repair and analysis.

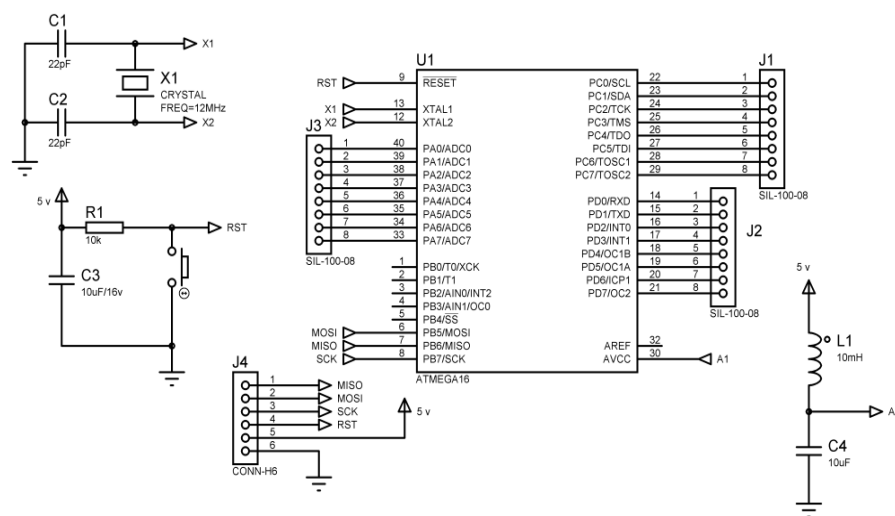

Figure 1. The block diagrams of the systems

Explanation of each block:

1. The keypad is used to enter the set point and start/turn off the system.
2. ATmega16 functions as a controller of the circuit work system through programmed software
3. LCD or display as output and to display the water temperature
4. The LM35 sensor is used to determine the water temperature.
5. Heater serves to heat the water.
6. Zero crossing AC heater control
7. Driver as a microcontroller interface with AC load and DC valve

In the process of distillation of water is done by heating sea water to become steam. To enter the heating temperature setpoint via the keypad.

The temperature input received by the keypad will be displayed on the LCD and processed by ATmega16, during the heating process the LM35 will read the temperature of the distilled water. the temperature read by the sensor will be used to regulate the heat of a heater with fuzzy control so that the temperature of the water remains stable according to the set point. In this tool, an automatic system is also made for filling seawater and removing the remaining salt water. The water level in this tool uses a float that is connected to a potential. When the water is in the top position, the microcontroller will activate the heating driver to heat the water until the water is in the middle position. If the water is in the middle position then the valve driver is active until the water is empty and if the water is in the lower or empty position then

the pump driver is active until the water is in the top position.

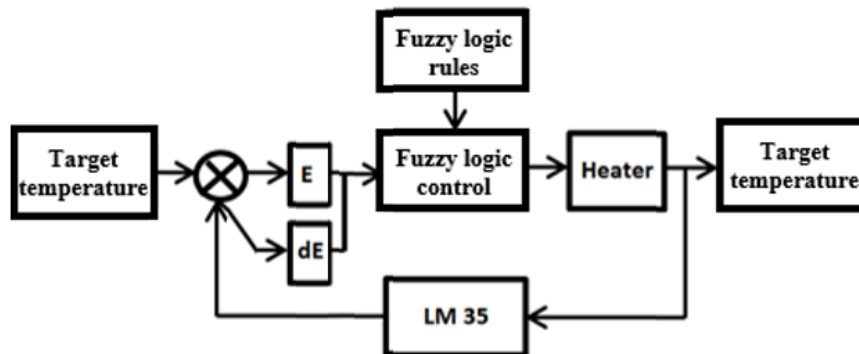

Figure 2. Block diagram of Fuzzy Logic Controller

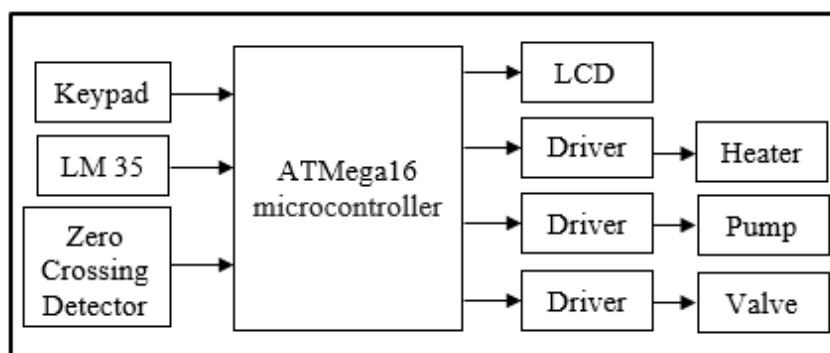

Figure 3. Minimum circuit ATmega 16 . system

In the block diagram of the Fuzzy Logic Controller in Figure 3 which is in the microcontroller. Fuzzy logic control has 3 variables, namely setpoint, error, and delta error. The fuzzy control input is the setpoint entered through the keypad and the temperature readings from the LM 35 sensor. The results from these inputs will produce an error and a delta error where error (E) is the difference between the setpoint or desired temperature and the current temperature while the delta error (dE) is the difference between the current error and the previous error. The results of fuzzy processing on the microcontroller will produce an ignition angle that is used to adjust the heater.

Mini ATmega16 . design

In the minimum system design, the ATMEGA 16 microcontroller is used as the main component that functions as the controller of this tool.¹¹ The selection of ATMEGA 16 is adjusted to the capacity of

the program you want to make, the memory capacity of the ATMEGA 16 microcontroller is quite large as we know in the datasheet. So in this series of thesis, the ATMEGA 16 microcontroller is the most suitable. The circuit diagram for the minimum system using ATmega 16 is shown in Fig The explanation for the ATmega 16 pin configuration is as follows:

1. PORT A0 (ADC0) is used as input from the LM 35 temperature sensor.
2. PORT A1(ADC1) is used as a potentiometer input which is connected to a float.
3. PORT A6 (ADC6) is used as an output to activate the pump driver
4. PORT A7 (ADC7) is used as an output to activate the valve driver
5. PORT C0-C7 and PORT D7 are used as input from the Keypad for 16 characters.
6. PORT B0-B7 is used as LCD output.
7. PORT D0-D1 is used for serial communication Rx and Tx.

According to the datasheet, the LM35 is a temperature sensor that has multiple output voltages with an output change of 10mV for every 1°C increase. In the above circuit the output of the LM35 sensor

$$\text{Resolution} = \frac{2.56V}{2^n - 1} = \frac{2.56V}{2^3 - 1} = 10mV \quad (12)$$

From this resolution, it can be seen that the LM35 output voltage can be read by the ADC microcontroller without adding a voltage amplifier circuit because the ADC resolution is 4.89 mv/step.

Design of Zero Crossing Detector

The zero crossing detector is used to detect a 220 volt AC sine wave as it passes through the zero voltage point. Opposite the zero point detected is a transition from positive to negative and a transition from negative to positive.^{12,13} Based on the output design that will be used almost entirely using high voltage equipment. That's why the ZCD design is one that is used to detect zero from the positive and negative crosses of high voltages.¹⁴ Zero crossing detector circuit is shown in the picture calculation of the Zero Crossing Detector circuit and component selection as follows,

$$V_p = V_{op} = V_{rms} \times \sqrt{2} \quad (3.17)$$

$$V_p = 220 \times 1.414 \quad (3.18)$$

$$V_p = 311.12 \text{ volt} \quad (3.19)$$

$$V_{dc} = 0.636 (V_{op} - 2V_d) \quad (3.20)$$

$$V_{dc} = 0.636 (311.12 - 2(0.7)) \quad (3.21)$$

$$V_{dc} = 188.89 \text{ volt} \quad (3.22)$$

For the recommended current through the input circuit dc isolator $I_{opto} = 100mA$ so the calculation is as follows,

$$V_{dc} = V_{opto} + V_{led} \quad (3.23)$$

$$V_{cc} = I_{opto} * R_{opto} + V_{led} \quad (3.24)$$

$$R_{opto} = \frac{V_{dc} - V_{led}}{I_{opto}} \quad (3.25)$$

$$R_{opto} = \frac{188.89 - 2}{100mA} \quad (3.26)$$

$$R_{opto} = 1868.9 \text{ ohm} \quad (3.27)$$

Based on these calculations, using $R_1 = R_{opto} = 2K \text{ ohms}$.

For the recommended current through the dc insulator input circuit $I_c = 2mA$ so the calculation is as follows,

$$V_{cc} - V_{ce} - V_c = 0 \quad (3.28)$$

$$V_{cc} - V_{ce} - I_c \cdot R_c = 0 \quad (3.29)$$

$$R_{pullup} = \frac{V_{dc} - v_{ce}}{I_c} \quad (3.30)$$

$$R_{pullup} = \frac{5 \text{ volt} - 1 \text{ volt}}{2mA} \quad (3.31)$$

$$R_{pullup} = 2000 \text{ ohm} \quad (3.32)$$

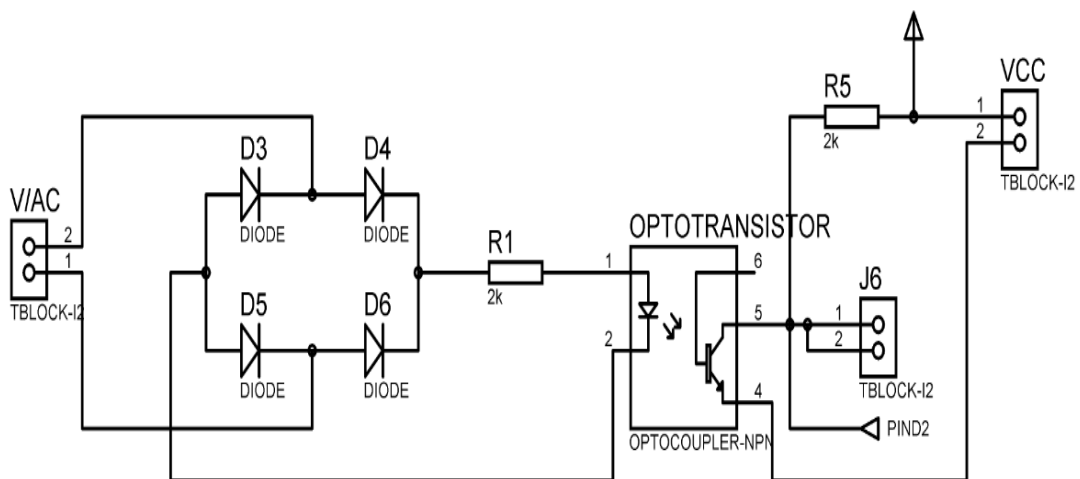

Figure 5. Zero Crossing Detector circuit schematic

Result and Discussion













The purpose of testing this circuit is to find out whether the minimum ATmega 16

system circuit can function properly or not. The test is carried out by testing the ports owned by the ATmega 16 microcontroller. The ports are connected to the input and

output devices used in this final project. These devices include: LCD and ADC readings. The way is first the microcontroller IC is filled in the program using the AVR Studio 4 software. After that the program is compiled with the aim of knowing whether the program still has errors or not. To download the program, it is done by connecting the microcontroller directly to the PC using parallel communication and using

the ISP downloader circuit as a buffer circuit. The equipment used in the process of testing this minimum system circuit are: the ATmega 16 microcontroller circuit module along with an LCD module as an output port indicator, a power supply circuit as a power supply, a connector cable, an ISP downloader circuit and a PC set along with AVR Studio 4 software.

Table 1. Minsis ATmega 16 input and output testing

Input	Output	Condition	Micro-controller	LCD
LM 35		80 °C	0.80 V	
		85 °C	0.853 V	
		90 °C	0.902 V	
		95 °C	0.95 V	
		100 °C	1 V	
Keypad 4x4		80 °C	-	
		85 °C	-	
		90 °C	-	
		95 °C	-	
		100 °C	-	
	Driver Pump (Relay)	ON	4.8 V	
		OFF	0 V	-
	Driver Valve (Relay)	ON	4.8 V	
		OFF	0 V	-

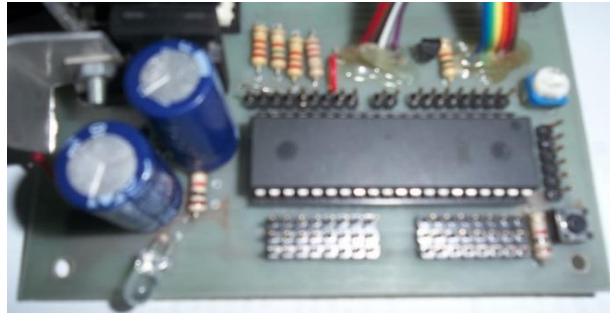

Figure 6. Minimum system

Table 2. The comparison of the sensors uses a temperature thermometer

No.	X (°C)	Y (°C)	e (%)
1	75	75.2	0.26
2	76	76	0
3	77	77.3	0.38
4	78	78	0
5	79	79.2	0.25
6	80	80.2	0.25
7	81	81	0
8	82	82	0
9	83	83.2	0.24
10	84	84.4	0.47
11	85	85.3	0.35
12	86	86	0
13	87	87.2	0.22
14	88	88	0
15	89	89.4	0.44
16	90	90.2	0.22
17	91	91	0
18	92	92	0
19	93	93.4	0.43
20	94	94.2	0.21
21	95	95	0
22	96	96.3	0.31
23	97	97.4	0.41
24	98	98.4	0.4
25	99	99.3	0.3

The listing program that is downloaded to the microcontroller is made to turn on PortA which is connected to the LM 35 temperature sensor as an ADC reading, PortB is

connected to the LCD and PortD is connected to the zero crossing detector, AC Driver. The test program can be seen in the appendix at the end of the research report.

After the program has been downloaded to the microcontroller, the devices connected to the minimum microcontroller system can function properly. connected to port A can be read. The LCD connected to PortB can display messages according to what is written in the program. Zero crossing detector, AC Driver connected to PortD can also read input properly on a minimum microcontroller system. The test results can be seen in Table 1.

Temperature sensor testing is done to test the reliability of the sensor. The sensor used is the LM 35 temperature sensor with a range of 0-150°C. The comparison of the sensors uses a temperature thermometer. The results of the test are shown in table 2

Conclusion

Based on the results of the application, testing and analysis of temperature settings on seawater distillation equipment using a fuzzy logic controller, it can be concluded:

1. The distillation device can work properly using an ATmega 16 microcontroller. This tool is equipped with a keypad and a 35 lm temperature sensor displayed on the LCD. This tool can also work automatically because seawater can be pumped in if the heater is empty and can also remove distilled water.
2. This tool can also set the temperature set point via the keypad from 80°C - 100°C with a temperature error of 0.18%. The error has no effect on system performance.
3. The fuzzy logic controller to regulate the temperature with input error and delta error with the output angle of ignition from 0° – 165° can already be applied to the distillation apparatus by controlling the heater.
4. By applying fuzzy logic as a temperature controller, the temperature response to time is obtained which has ErrorSteady state = 0.26%, Max.Overshoot = none, settling time = 103 minutes, peak time = none, rise time = 37 minutes. Based on the curve above, it shows that using a fuzzy controller does not experience overshoot

so that the temperature can be maintained properly.

5. With a set point of 80°C – 100°C, the quality of water that meets the requirements for drinking water is obtained. The difference in the quality of the water produced with different temperature set points lies in the difference in acid-base pH. And from the time it takes to produce 1 liter of fresh water, the temperature of 100°C has the best time efficiency because the time it takes to produce fresh water is 3.5 hours. So that the energy required to perform distillation is smaller than other temperatures.

References

1. M. Risnain. The Concept of the Archipelagic Province and Archipelagic State in the Perspective of National and International Law. *Lampung J. Int. Law*, 2021; 3(2): pp.73–84 doi: 10.25041/lajil.v3i2.2367.
2. D. De., Review. Water desalination methods. 2021.
3. I. Soesanti, R. Syahputra. A Fuzzy Logic Controller Approach for Controlling Heat Exchanger Temperature. *Journal of Electrical Technology UMY*. 2019; 3(4): pp. 117–124 doi: 10.18196/jet.3462.
4. E. Irmak, I. Colak, O. Kaplan, N. Guler, Design and application of a novel zero-crossing detector circuit. In 2011 International Conference on Power Engineering, Energy and Electrical Drives. 2011. pp. 1-4. doi: 10.1109/PowerEng.2011.6036535.
5. A. Gupta, R. Thakur, S. Murarka. A Review on Zero Crossing Detector 1,2,3. *India IJECT J*. 2012;7109: pp. 366–368.
6. Atmel. Atmega 16(L). Juli 2010. Available from: www.atmel.com.
7. Farida Agustini Widjajati. Application of Fuzzy Inference System on Rainfall Prediction in North Surabaya. *ITS Journal of Science and Arts*. 2012 Sept; 1(1). ISSN: 2301-928X
8. Ardiansyah, F. ZeroCrossingDetector. 2013.

9. Homig, H. E. Seawater and Seawater Distillation. Vulkan-Verlag. University of California. 202 h. 1978.
10. Kodoatie, R.J., Sjarief, Rustam. Integrated Water Resources Management. Yogyakarta: Andi; 2005.
11. Kusumadewi S, Purnomo H. Fuzzy Logic Application for Decision Support. Yogyakarta: Graha Ilmu; 2004.
12. Marsum WA. Bar. Drinks and Service. Yogyakarta:Publisher Andi;2004.
13. Meinawati, R. Evaporation Type Seawater Desalinator Design. *Essay*. Bogor: Agricultural Institute. 50 h; 2010.
14. Nanawi, G. Water Quality and Its Use in Agriculture. Jakarta: Directorate of Vocational Secondary Education. 36 h; 2001.
15. Salvato, J. A. Environmental engineering and Sanitation. California :Wiley-Interscience. University of California. 919 h; 1972.
16. Zadeh, L. A. Fuzzy Sets. Information and Control, 8. 1965: 338-353.
17. Gunawan. Anomaly covid-19, positive impact of corona virus for the world. Purwokerto: Publisher CV IRDH; 2020.