



Impact of Exports and Foreign Direct Investment on Gross Domestic Product in Sub-Sahara Africa

Niyungeko Antoine
Business Department,
Horizons University, 75003,
France
niyungantoine@yahoo.fr

ABSTRACT

Bhagwati developed a hypothesis that expected economic growth (EG) enhancing impact of exports (EXP) and foreign direct investment (FDI) interaction. This paper checks the validity of the Bhagwati hypothesis by examining the moderation and mediation effect of EXP in the relationship between FDI and Gross domestic product for Sub Sahara Africa countries (SSA) during 2018 period. To achieve the article purpose, normality test, robust regression, and causal analysis using bootstrapping procedure were performed using R programming environment. The correlation results revealed a strong correlation between FDI-EXP-GDP. The coefficient of the robust regression of the interaction term of EXP and FDI was found positive, and statistically significant. The result of the mediation analysis showed that indirect relationship of FDI was found positive and significant whereas direct relationship was not significant. The results are consistent with the previous studies, theory, and Bhagwati hypothesis. Theoretical and practical implications were presented.

Keywords: Exports, Foreign Investment, Sub-Sahara, Gross Domestic Product, Mediation

| Received January 2021 | Accepted July 2021 | Available online August 2021 |
| DOI: <http://dx.doi.org/10.18860/mec-j.v5i2.10922>

INTRODUCTION

Increasing economic growth is among the priority of the world agenda 2030 on sustainable development goal. According to the agenda, countries should maintain their economic growth at 7% annually (UNDP, 2020). However, the agenda 2030 did not indicate factor that would increase economic growth at such increase rate. According to Daniel and John (2017) the Bhagwati hypothesis expected economic growth enhancing impact of EXP and FDI interaction. Nevertheless, results on the impact of FDI and EXP on economic growth are mixed. Some studies concluded that FDI has positive impact on economic growth (Khun, 2018). While some other studies found that FDI had negative impact on economic growth. According to the study of Norimah, Dayang and Emilda (2017) EXP influenced economic growth while FDI had no influence on economic growth in Malaysia. Even though some studies found positive impact of FDI on economic growth; they did not explain how FDI contribute to economic growth. Moreover, the

Impact of Exports and Foreign Direct Investment.....

effect of the interaction between FDI and EXP on economic growth was neglected by previous studies in SSA. This way of doing provides little information about the mechanism by which FDI really contribute to economic growth.

There are many studies that analyzed the impact of FDI and trade on economic growth in general, and particularly in Africa. FDI and trade got much attention because there is a belief in policymakers, and academics that these variables contribute significantly on economic growth. For instance, EXP and FDI are supposed to be the main drivers of economic growth (Diouf & Hai, 2017). Lawrence, Emmanuel and Eric (2019) used structural equation modeling technique while analyzing data from 34 SSA countries for the period 1996–2016. Their results indicated reducing effect of FDI on E.G. Using Fully Modified Ordinary Least Squares (FMOLS), these authors concluded that Asia's FDI and trade significantly contributed to economic growth in 13 West African countries. Bhavish, Nitisha & Sheereen (2016) examined the impact of FDI on EG using a panel of 32 Sub-Saharan African countries. Data collected covered the period 2008-2014. Static panel regression techniques and dynamic panel estimates were used to analyze the causal link among the variables. Their result showed that FDI had a positive and significant impact on economic growth in 32 Sub-Saharan African countries examined. The findings of Lawrence, Emmanuel & Eric (2019) and those from Bhavish, Nitisha & Sheereen (2016) are contradictory. It seems results vary according to the methods used in data analysis.

Mona (2015) explored the relationship between economic growth and the inflow of FDI in the SSA region. A panel data for 41 sub SSA covering 2005-2013 periods was used. The results indicated that FDI had a positive effect on economic growth in the receiving countries. Daniel and John (2017) assessed the validity of the Bhagwati hypothesis by examining the extent to which the interaction of EXP and FDI had an impact on economic growth for a sample of 45 African countries during the period 1990–2014. They used an augmented endogenous growth model with the help of a dynamic system generalized method of moment (GMM) estimation technique. They concluded on the supporting findings for the Bhagwati hypothesis. In other words, the interaction between FDI and EXP had economic growth enhancing effect in African countries. Using data covering 1996 to 2016 periods, Tsatsaridis (2017) conducted ordinary least square regressions and co-integration tests to examine 43 countries in the Sub-Saharan Africa region. He concluded that FDI inflows had a statistically important effect on GDP growth in the country analyzed. Keho (2017) used Autoregressive Distributed Lag bounds ,cointegration, and the Toda and Yamamoto Granger causality tests, and found that trade openness had positive effects on economic growth both in the short and long-run in Cote d'Ivoire.

Regarding these contradictory findings, it becomes impossible to predict the impact of FDI and EXP on GDP in receiving country. Moreover, it is impossible to anticipate the effect of the interaction of FDI and EXP on EXP. Finally, the way FDI contributed to economic growth is not well known. Many SSA countries are among the world poorest countries. Increasing economic growth becomes indispensable. However, SSA countries

cannot increase economic growth without knowing the factors that contribute their economic growth. The impact of the interaction of FDI and GDP is not known in SSA.

The literature review analyzed shows contradictory results on the impact of FDI on GDP. Various methods were used leading to inconsistent conclusion. The contradictory results may be due to non-compliance with the assumptions of the method used. According to Casson and Farmer (2014) linear regression for instance, is an influential statistical tool that can elucidate and forecast real-world phenomena; however, a misunderstanding of its assumptions can lead to erroneous and confusing conclusions. According to Jan, Evžen and Mathilde (2010) panel studies are expected to find relatively lower spillover effects.

In this context of the fall of FDI in SSA, it is indispensable to understand how FDI contributed to GDP to better find alternative strategy to reduce the negative impact resulting from the fall of FDI inflows in SSA. United Nations Conference on Trade and Development (2021) indicated that FDI inflows to sub-Saharan Africa reduced by 12% to \$30 billion. Therefore, the main purpose of this paper is analyzing the impact of FDI and EXP on GDP through investigating moderation and mediation effect of EXP in the relationship between FDI and GDP. Specifically, the study tends to achieve the following sub-objectives: To investigate the relationship between FDI and GDP in SSA, To investigate the impact of the interaction of FDI and EXP on GDP in SSA, To examine the relationship between FDI and EXP in SSA, To analyze the mediation effect of EXP in the relationship between FDI and GDP. The main question of this study is what was the impact of FDI and EXP on GDP in SSA?

THEORETICAL REVIEW

Many theories were developed to explain trade between countries. Others were developed to explain how FDI has effect on GDP. Foreign Direct Investment (FDI) refers to cross border investment made by a resident in one economy in an enterprise in another economy, with the objective of establishing a lasting interest in the invested economy. FDI is also described as investment into the business of a country by a company in another country, (Sudha, 2013). Sudha added that foreign investment is motivated by availability of cheap labour, uninterrupted availability of raw material, less production cost compared with other developed countries, and quick and easy market penetration. The Organization for Economic Cooperation and Development "OECD"(2002) suggested that host countries would benefit from FDI. FDI triggers technology spillovers, assists human capital development, contributes to international trade integration, helps improve environmental and social conditions, helps create a more competitive business environment, encourages leading to more socially responsible corporate policies and enhances enterprise development. In addition, all of these factors contribute to higher economic growth, which is the most potent tool for alleviating poverty in developing countries (Kowalski, 2011).

The World Bank (2020) provided indicators used in ease doing business assessment and defined each of them. The following variables are defined according to World Bank. *GDP*

Impact of Exports and Foreign Direct Investment.....

(constant 2010 US\$): GDP at purchaser's prices is the sum of gross value added by all resident producers in the economy plus any product taxes and reducing possible subsidies not included in the value of the products. It is calculated without reducing depreciation of produced assets or for depletion and degradation of natural resources. *Foreign direct investment net inflows* (current US\$) (FDI): is the sum of equity capital, reinvestment of earnings, and other capital. *Direct investment* refers to a category of cross-border investment linked with a resident in one economy, having control or a significant degree of influence on the management of an enterprise that is resident in another economy. Having at least 10 percent of the ordinary shares of voting stock was the criterion for determining the existence of a direct investment relationship.

Exports of goods and services (current US\$) (EXP) is the value of all goods and other market services provided to the rest of the world. They do not consider the value of merchandise, freight, insurance, transport, travel, royalties, license fees, and other services, such as communication, construction, financial, information, business, personal, and the government services. Compensation of employees and investment income and transfer payments are excluded.

Two inconsistent theories were used to characterize the impact of FDI on economic growth in host country. Rakhmatullayeva et al. (2020) mentioned: i) the theory of economic modernization (grounded on neoclassical and endogenous growth theories); ii) the theory of the dependence of the economy from FDI. According to them, the neoclassical theory of economic growth established by Solow and Rostow considers FDI as a significant growth factor for emerging countries. In the Rostow model, FDI constitutes a source of capital and technological transfers to the country required for economic transformation. Solow emphasized the increase in foreign capital and technological growth as important variables in the growth of production and, accordingly, development. Theories of endogenous growth clarify the positive impact of FDI on the country's economic growing through the extension of knowledge and the gaining of new skills by personnel, the introduction of substitute management methods and organizational mechanisms, and, as a result, the quick spread of technology and increased efficiency of resident companies.

On the other hand, dependency theory argued that transnational companies can avoid economic development by gathering out local entrepreneurs, falling income distribution, dropping consumer welfare, and introducing unsuitable consumption patterns in host countries.

In the light of endogenous theory, Mahembe and Odhiambo (2014) indicated that FDI contributes to economic growth through (i) encouraging the adoption of new technologies in the production process through technological spillovers; and stimulating knowledge transfers, both in terms of labour training and skill acquisition, and also by introducing alternative management practices and better organizational arrangements. These authors added that on economic growth in the mid-1990s. FDI is a complex package that contains physical capital, products and services, production techniques,

managerial skills, marketing expertise, advertising and business organizational processes.

Daniel and John (2017) evaluated the extent to which the interaction of EXP and FDI had an impact on economic growth for a sample of 45 African countries during the period 1990–2014. They concluded that the interaction between FDI and EXP had economic growth enhancing effect in African countries.

Based on this result we can state our alternative hypothesis:

H₁. The interaction of foreign direct investment and export had positive impact of gross domestic product in SSA.

Tsatsaridis (2017) examined 43 countries in the Sub-Saharan Africa region. He concluded that FDI inflows had a statistically important effect on GDP growth in the country analyzed. Mona (2015) used a panel data for 41 sub SSA covering 2005-2013 periods and found that FDI had a positive effect on economic growth in the SSA.

H₂. Foreign direct investment had positive impact on gross domestic product in SSA.

Keho (2017) used Autoregressive Distributed Lag bounds to examine cointegration and the Toda and Yamamoto Granger causality tests, and found that trade openness had positive effects on economic growth both in the short and long-run in Cote d'Ivoire.

As far this study includes exports in the analysis, it is useful to present some theories related to trading overseas. Among those theories, we find comparative advantage, absolute advantage, availability theory, and gravity theory, ect.

Comparative Advantage: Satya (2015) indicated that technological superiority, resource endowments, demand patterns, and commercial policies are among those factors that provide comparative advantage. A country has a comparative advantage if it can produce a good or service at a lower opportunity cost than another country (Kimberly, 2020). Mulugeta (2017) explained that comparative advantage arises from differences in national factor endowments. As result the more abundant a factor, the lower its cost. As trade consequence, countries will export goods that make intensive use of locally abundant factors and import goods that make intensive use of factors that are locally scarce. Standard trade theory asserts that a country's comparative advantage in trade is based on its factor endowments (labour or capital) and that it will export those commodities that use its relatively abundant factor most intensively, (United Nations Conference on Trade and Development, 2016).

Ukwandu (2015) showed that the theory of comparative advantage cannot be applied in African countries and presented the assumptions that support the comparative advantage: Two countries and two goods do exist; Perfect competition will take place (both on the commodities and factor markets); Production costs are measured in terms of labor and commodity value is measured in terms of the hours / days of labor required for its production; Labor is the only competitive factor and other factors, such as natural capital, are disregarded; The labor costs are comparable in developed as well as

developing countries; Labor within a country is perfectly mobile but perfectly motionless between countries; Foreign trade does not take place between countries; Transport is not seen as a manufacturing element.

The theory of comparative advantage was criticized. For instance Ukwandu (2015) indicated that Ricardo's theory is based on only two countries and two commodities. The reality proves the irrelevance of the theory to development in Africa, as the continent contains 53 countries which export many commodities to other countries of the world. Since Africa trades with many countries, and in different commodities, it is therefore, difficult for the theory to be applied to this continent. In contrast of the conclusion of Ukwandu (2015) related to no applicability of the theory of comparative advantage in Africa, Africa is naturally endowed in many factors like healthy soils suitable for agricultural cultivation, sufficient water supply for irrigation, transport and hydroelectric generation, abundant minerals, etc. Africa considered as one unit, and the rest of the world as another unit, can use the comparative advantage theory to penetrate the international market by using efficiently its natural resources.

Absolute Advantage: Trade is based on absolute or competitive advantage rather than on comparative advantage. That is, a country that produces a good more cheaply will dominate the international market and outdo its competitors (United Nations Conference on Trade and Development, 2016). The concept of absolute advantage developed by Adam Smith refers to a country having higher (absolute) productivity or lower cost in producing a commodity compared to another country. The notion of absolute advantage refers to efficiency in production. As consequent, a country that produces a good more cheaply will dominate the international market and outdo its competitors. Satya (2015) explained that the Adam Smith's principle of "absolute advantage" and David Ricardo's principle of "comparative advantage," in general, are based on the technological superiority of one country over another country in producing a commodity.

Availability Theory: Availability theory developed by Kravis stated that a country tends to import products that are not available at home (Gandolofo, 2014). It is the domestic availability or non-availability of goods that governs the pattern of trade. The availability is determined by natural resources, technological progress and product differentiation (Gouranga & Kyunggi, 2012).

Gravity Theory: Saleh, Sokvibol and Lu (2019) indicated that gravity model has become a popular research device used by the researchers and policy-makers around the world; it is considered as one of the most appreciated models in the literature of international economics. The model states that the volume of trade between any two countries is proportional to the product of their GDPs, and a distance deterrence function where distance is broadly construed to include all factors that might create trade resistance (Tamás & Fischer, 2014). According to the report of the United Nations (2017) strong evidence shows that simplifying and modernizing trade procedures, countries can become more competitive and increase their overall flows, resulting in higher state

revenue and other socioeconomic benefits of increased trade such as job creation, poverty reduction, and improved quality of life. The report confirms the existence of direct link between gross domestic per capita and the rate of implementation of trade facilitation measures.

Mukhtarov et al. (2019) examined the impact of foreign direct investment on exports in Jordan and found a positive and statistically significant impact of FDI on export in the long-run. Sultan (2013) indicated that FDI encourages exports by facilitating the host countries access to customers in global, regional and home-country markets, helping in improving productivity of labour force through training of local workforce and upgrading technical and managerial skills. FDI has direct effects through increasing exports by foreign affiliates themselves. He added that FDI has indirect effect through spillover effect of multinational companies on local firms' export activities.

H₃. Foreign direct investment had positive impact on exports in SSA.

Tingley et al. (2014) indicated that the standard procedure for analyzing causal mechanisms in applied research is called mediation analysis, where a set of linear regression models are fitted and then the estimates of "mediation effects" are computed from the fitted models. According to Pardo & Román (2013) to have mediation: Independent variable (FDI) and dependent variable (GDP) must be related; Independent variable (FDI) and mediator variable (EXP) must be related; Mediator variable (EXP) and dependent variable (GDP) must be related once the effect of independent variable (FDI) is controlled; The relationship between independent variable (FDI) and dependent variable (GDP) must be significantly reduced when controlling the effect of mediator variable (EXP). If one of these conditions is not respected, there is no mediation.

Topi (2011) showed how GDP can be calculated using three different ways. It can be obtained by value added (or production) approach, difference between gross output of different industries and intermediate inputs, to avoid double counting. Using income (by type) approach, it is the sum of all income earned by different factors of production. Finally the GDP can be determined by final demand (or expenditures) approach, which measures the activities, such as investment and consumption across different industries and imports deducted from exports. Using the final demand approach, the equation become: $GDP = C + I + G + (X - M)$ where C is consumption of final goods and services by the households, I is investment in things such as plants, equipment and software, G is government expenditures on goods and services, X is exports and M is imports.

Based on the previous empirical results and the mediation analysis process, we can state our alternative hypothesis.

H₄. There was a mediation effect of export in the relationship between foreign direct investment and gross domestic product in SSA.

METHODOLOGY

To depict the impact of exports and foreign direct investment interaction on gross domestic product in Sub-Sahara Africa, quantitative approach was used. Literature review was performed to identify what has been done by previous studies, and to identify the limitation of performed researchers. Quantitative secondary data were collected from official World Bank Indicators (<https://data.worldbank.org/indicator>). GDP used in this research paper refers to the amount of gross value added by all resident producers in the economy plus any commodity taxes and minus any subsidies not included in the value of the goods, (World Bank,2020). EXP refers to the value of all products and other business services offered to the rest of the world including the value of goods, freight, insurance, transport, travel, taxes, license fees and other services, such as communications, building, financial services, computer services, business services, personal services and government services. They do not consider employee and investment benefit benefits, and transition payments, (World Bank, 2020). FDI is the amount of equity capital, earnings reinvestment, and other capital (World Bank, 2020). Statistical analyses were performed. Normality test was performed using Shapiro test. This test allows choosing statistical approach to be used in data analysis. As data were not normally distributed, robust regression was performed to analyze the impact of the interaction of FDI and EXP on GDP in SSA. Robust regression also was used to examine the impact of FDI on GDP and EXP. The choice of this method was based on the fact that robust methods have the advantage of down weighting deviating observations while estimating the model, yields reliable results even when the data deviate from normality assumptions (Andreas, Nüfer & Patrick 2018).

Spearman correlation was used to investigate the relationship between variables. To test the mediation effect of EXP in the relationship between FDI and GDP in SSA, bootstrapping procedure was used. Conversely to the mediation analysis procedure proposed by Baron and Kenny (1986), bootstrapping procedure was used because it does need data to be normally distributed. The main advantage of using robust methods is their capacity of down weighting deviating observations while estimating the model, produce reliable results even when the data are not normality distributed (Andreas, Nüfer & Patrick 2018). Annual data 2018 were collected for 40 Sub-Sahara African countries. To estimate the impact of the interaction of FDI and EXP on GDP in SSA, a robust regression model of the following form was applied by using the robust package in R programming environment.

$$GDP = \beta_0 + \beta_1 FDI * EXP + e$$

Where:

β_0 = Constant term

β_1 = Regression Coefficients

GDP=Gross Domestic Product (Dependent Variable)

FDI=Foreign Direct Investment

EXP= Exports

e = Error term.

RESEARCH RESULTS

Descriptive Statistics

To get a better understanding of the data, the Table 1 provides descriptive statistics of the data. Mean and median were used to analyze central tendency of the data. To measure the deviation around the mean, standard deviation was calculated. The minimum and maximum values were also presented. To test data normality, Shapiro Wilk normality test was used. Normality test was performed because the use of parametric procedures like correlation, regression, t tests, and analysis of variance, are based on the assumption that the data follow a normal distribution or a Gaussian distribution (Ghasemi & Zahediasl, 2012). According to these authors, in the presence of large enough sample sizes (> 30 or 40), the violation of the normality assumption should not have major problems. Spearman correlation was performed to analyze the correlation between variables under study. The Table 1 presents descriptive statistics. The amounts are in American dollar.

Table 1. Descriptive Statistics

Measures	GDP	FDI	EXP
Mean	38448552893.6	873334819.5	9269077707.5
Median	13404337884.2	402161428.1	4225386275.4
Standard deviation	96943475839.36	1250331290.13	19235137399.45
Minimum value	1165969815.4	983747.1	156055206.9
Maximum value	469376777277	5470685860	110144477441
P-value of Shapiro normality test	0.000	0.000	0.000
Skewness	13.39	3.80	17.30

Source Author's Computation based on World Bank Indicator data

The Table 1 shows great difference between mean and median for all variables. Regarding the results of the normality test, the null hypothesis of normal distribution was rejected as the p-value of the Shapiro normality test is less than 0.05. The skewness which should be near zero is far for the threshold for normal distributed data. The results of the skewness are in line with the Shapiro normality test confirming not normality of the data.

Correlation analysis

The analysis of the correlation between GDP -EXP-FDI helps understanding the relationship between variable. Thus, there cannot be a mediation effects when variables are not related. If there is a relationship among variables, this implies that one variable can be predicted by the other variable. To get first estimation of the relationship between variables under study, correlation analysis coefficients are presented in the Table 2. Pairwise correlation analysis was performed.

Table 2. Spearman's correlation Analysis

Variables	Spearman's rho	p-value
GDP-FDI	0.884***	< .001
GDP-EXP	0.925***	< .001
FDI-EXP	0.849***	< .001

Significance: * p < .05, ** p < .01, *** p < .001

According to Schober, Boer and Schwarte (2018) there is strong correlation when correlation coefficient is between 0.7 and 0.89. The correlation becomes very strong correlation when the correlation coefficient is greater than 0.9. Based on this statement, there was strong and positive correlation between GDP and FDI 0.884. The correlation was positive and strong also between FDI and EXP 0.849. However, the correlation was very strong and positive between GDP and EXP 0.925. The flags indicates that the null hypothesis that the correlation coefficient is null is rejected at p-value <.001 level.

Robust regression analysis

Regression allows understanding relationship between variables. It shows the variance of the dependent variable explained by independent variable. Finding such relationship can help to explain and predict dependent variable given the independent variable.

To test the hypothesis that the interaction of foreign direct investment and export had positive impact on gross domestic product in SSA, robust regression was used. The use of this technique is due to the fact that data deviates from normality assumption. Additionally, robust methods have the capacity of down weighting deviating observations while estimating the model, produce reliable results even when the data are not normality distributed (Andreas, Nüfer & Patrick 2018). The Table 3 shows the result of the robust regression.

Table 3. Impact of interaction of FDI and EXP on GDP

Coefficients	Estimate	Standard Error	t value	p-value
Intercept	4.706e+09	1.534e+09	3.068	0.00396 **
FDI:EXP	3.778e-09	6.989e-11	54.051	< 2e-16 ***
Multiple R-Squared	0.3576			

Significance: * p < .05, ** p < .01, *** p < .001

The equation can be written as follows: $GDP = 4.706e+09 + 3.778e-09FDI*EXP + e$

The effect of FDI and EXP on GDP is positive and statistically significant. Increasing one unit of FDI and EXP will produce increase effect of GDP of 0.3576. The variance explained

in the robust regression model by the interaction of FDI and EXP in variability of GDP was 36%. The findings are consistent with the previous studies especially Bhagwati's hypothesis. According to Daniel and John (2017) the Bhagwati hypothesis expected economic growth enhancing impact of EXP and FDI interaction. Based on this result, the hypothesis that the interaction of foreign direct investment and export had positive impact of gross domestic product in SSA is validated. The Table 4 presents the result of robust regression of FDI on GDP.

Table 4. Impact of FDI on GDP

Coefficients	Estimate	Standard Error	t value	p-value
Intercept	4.201e+09	1.169e+09	3.593	0.000925 ***
FDI	17.942	1.249	14.361	< 2e-16 ***
Multiple R-Squared	0.3948			

Significance: * p < .05, ** p < .01, *** p < .001

The result of the robust regression shows that the impact of FDI on GDP is positive and statistically significant. Increasing one unit of FDI will increase GDP by 17.942. The coefficient is significant at p-value <.001 level. The variance of GDP explained by FDI is 39%. Based on this finding, the hypothesis that foreign direct investment had positive impact on gross domestic product in SSA is validated. These results are consistent with the results of prior studies. Tsatsaridis (2017) conducted ordinary least square regressions and co-integration tests to examine 43 countries in the Sub-Saharan Africa region. He concluded that FDI inflows had a statistically important effect on GDP growth in the country analyzed. Halizam et al. (2021) concluded that FDI contributed positively and significantly on Malaysia economic growth.

The findings of this study are consistent with the theory of economic modernization (based on neoclassical and endogenous growth theories which consider FDI as a significant growth factor for developing countries. FDI is considered as a source of capital and technological transfers to the country needed for economic transformation. Solow emphasized the increase in foreign capital and technological growth as important variables in the growth of production and, accordingly, development. Theories of endogenous growth clarify the positive impact of FDI on the country's economic growing through the extension of knowledge and the gaining of new skills by personnel, the introduction of substitute management methods and organizational mechanisms, and, as a result, the quick spread of technology and increased efficiency of resident companies. This new technology, knowledge and managerial improvement resulted from FDI may be the source of increase in EXP in SSA. The Table 5 presents the results of the robust regression on FDI on EXP.

Table 5. Impact of FDI on EXP

Coefficients	Estimate	Standard Error	t value	p-value
Intercept	1.096e+09	8.921e+08	1.229	0.227
FDI	7.529	1.215	6.198	< 2e-16 ***
Multiple R-Squared	0.2831			

Significance: * p < .05, ** p < .01, *** p < .001

The result of the robust regression shows that the impact of FDI on EXP is positive and statistically significant. Increasing one unit of FDI will increase EXP by 7.529. The coefficient is significant at p-value <.001 level. The variance of EXP explained by FDI is 28%. Based on this finding, the hypothesis that foreign direct investment had positive impact on export in SSA is validated. The results are consistent with prior studies, Mukhtarov et al. (2019) examined the impact of foreign direct investment on exports in Jordan and found a positive and statistically significant impact of FDI on export in the long-run. Sultan (2013) indicated that FDI encourages exports by facilitating the host countries access to customers in global, regional and home-country markets, helping in improving productivity of labour force through training of local workforce and upgrading technical and managerial skills. FDI has direct effects through increasing exports by foreign affiliates themselves. He added that FDI has indirect effect through spillover effect of multinational companies on local firms' export activities. Selimi, Reçi, and Sadiku (2016) found that FDI positively affect export performance in Western Balkan countries examined. Keho (2017) used Autoregressive Distributed Lag bounds to examine cointegration and the Toda and Yamamoto Granger causality tests, and found that trade openness had positive effects on economic growth both in the short and long-run in Cote d'Ivoire. The Table 6 presents the results of causal mediation analysis.

Table 6. Mediation effect of EXP in the relationship between FDI and GDP

Coefficients	Estimate 95% CI	Lower 95% CI	Upper	p-value
ACME	56.799	5.345	129.18	< 2e-16 ***
ADE	-10.940	-49.347	9.95	0.48
Total Effect	45.859			< 2e-16 ***
Proportion Mediated	1.239	7.714	83.60	< 2e-16 ***
		0.454	1.95	

Significance: * p < .05, ** p < .01, *** p < .001

The result of causal mediation analysis indicates positive and significant indirect effect of FDI on GDP via EXP. The average causal mediation effect (ACME) is 56.799 and is significant at p<0.001 level. The average direct effect (ADE) is negative and not significant. The total effect which is the sum of ACME and ADE is positive and significant at p<0.001 level. The proportion mediated is ratio of ACME per total effect and is positive and significant. These results indicate that in SSA FDI contributed to GDP growth by

increasing EXP. Direct relationship between FDI and GDP is small and not significant while indirect effect is great and significant. These findings are consistent with the result of Mamingi and Martin (2018) who indicated that even though FDI positively affects economic growth, its impact is minimal when considered in isolation. However, the significant effect of FDI is rather indirect than direct.

To choose the strength and the type of the mediation, the variance accounted for (VAF) that indicates the share of the indirect effect in the total effect was used. If VAF is less than 20%, the indirect effect is not significant; therefore, there is no mediation. On one hand if the VAF value is between 20% and 80%, there is partial mediation. On the other hand, if the VAF value is greater than 80%; it implies full mediation (Hadi, Abdullah & Sentosa, 2016). In this study, the VAF value is 123.9%. Therefore, there EXP fully mediated the relationship between FDI and GDP in SSA. Based on the findings of the mediation analysis, the hypothesis that there was a mediation effect of export in the relationship between foreign direct investment and gross domestic product in SSA was validated.

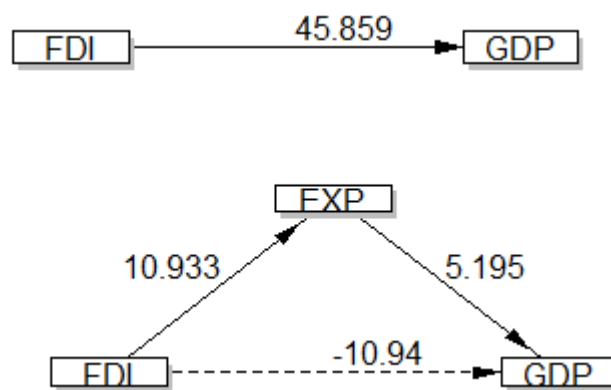

Figure 1: Results of causal mediation analysis

The findings are consistent with the previous studies especially Bhagwati’s hypothesis. According to Daniel and John (2017) the Bhagwati hypothesis expected economic growth enhancing impact of EXP and FDI interaction. Bhavish, Nitisha and Sheereen (2016) examined the impact of FDI on economic growth in 32 Sub-Saharan African countries, and found that FDI had a positive and significant impact on economic growth. Daniel and John (2017) assessed the validity of the Bhagwati hypothesis by examining the extent to which the interaction of EXP and FDI had an impact on economic growth, and concluded that the interaction between FDI and EXP had economic growth enhancing effect in African countries. Mamingi and Martin (2018) indicated that direct effect of FDI on GDP is less than indirect effect when FDI is analysed single.

CONCLUSION

The main purpose of this paper was analysing the impact of FDI and EXP on GDP. Specifically, the study investigated the relationship between FDI and GDP in SSA, analysed the association between GDP and EXP in SSA, investigated the impact of the interaction of FDI and EXP on GDP in SSA, and analysed the mediation effect of EXP in the relationship between FDI and GDP. Spearman correlation revealed the existence of a strong correlation between FDI-EXP-GDP. Robust regression showed that the interaction between FDI and EXP had a significant and positive impact on GDP during 2018. The robust regression showed that FDI had positive and significant effect on GDP and FDI. Finally, the causal mediation analysis indicated that there was a significant indirect effect of FDI on GDP via EXP. That means increasing FDI increased EXP which in return increased GDP.

Theoretical Implications

The present research contributes to the current literature by providing a deep understanding on the effect of the inter-relationship between FDI and EXP on GDP. Additionally, it shows how FDI contributes indirectly to GDP. The way FDI contributes to GDP did not get much attention from the previous studies. This study shows how FDI increased GDP through increasing EXP. The results are not surprising because there was a strong and positive relationship among variables. Moreover, increasing EXP increases GDP as EXP is included in the equation of GDP calculation. The study demonstrated the hypothesis that the indirect effect of FDI on GDP was greater than direct effect.

Practical Implications

As indicated by the United Nations Conference on Trade and Development (2021) FDI inflows to sub-Saharan Africa reduced by 12% to \$30 billion. This study anticipates what should be the impact of this fall on SSA's gross domestic product and on its exports. EXP and GDP can be affected negatively by this fall because EXP and GDP were found associated positively to FDI. If an increase in FDI increases GDP, a fall in FDI may result in a fall in EXP and GDP. Policymakers in SSA should increase and diversify its exports to reduce the impact of this fall on GDP. Policymakers should also define a clear strategy of attracting foreign investors especially those who tend to stimulate exports of goods, and services. Policymakers should also find alternative strategies of financing exports not relying only on FDI. Based on the gravity theory developed previously, SSA country should develop and increase trade intra-region by reducing barriers among them. Base on endogenous theory presented; SSA should bring modern technology from the exports made to increase the quantity and the quality of their exports.

Research Limitation

This study has limitation that forbids generalisation of the findings. The sample used in this study is related to SSA countries only. The sample size is too small to generalize the results of this study on the impact of FDI and EXP on GDP. Other studies should be conducted and should include more samples to get generalizable findings. This study

tested the mediation effect of EXP in the relationship between GDP and FDI. However, other components of the equation of GDP based on expenses equation ($GDP = C + I + G + (X - M)$), e.g private consumption, investments, government expenses, and import were not examined. Other studies should be conducted to test these components of the equation of GDP to provide better understanding of the spill overs of FDI in SSA.

REFERENCES

- Andreas, A, Nüfer, Y. A. and Patrick, J. F. G. (2018). A robust bootstrap test for mediation analysis. Retrieved 20.11.2020 from <https://econpapers.repec.org/paper/emseureri/109594.htm>
- Baron, R.M. and Kenny, D.A. (1986). The Moderator-Mediator Variable Distinction in Social Psychological Research: Conceptual, Strategic, and Statistical Considerations. *Journal of Personality and Social Psychology*, 51(6), 1173-1182
- Bhavish, J., Nitisha, C. & Sheereen, F. (2016). Foreign direct investment & economic growth in Sub-Saharan Africa: an empirical study. *Theoretical Economics Letters*, 6, 798-807.
- Casson, R. F. & Farmer, L. (2014). Understanding and checking the assumptions of linear regression: a primer for medical researchers. *Clinical and Experimental Ophthalmology*, 42, 590–596 doi: 10.1111/ceo.12358.
- Daniel, S. & John, E. (2017). Effects of trade and FDI on economic growth in Africa: an empirical investigation. *Transnational Corporations Review*, 9 (2). *Taylor & Francis Journals*, 9(2), 66-87.
- Diouf, M. & Hai, Y. L. (2017). The impact of Asian foreign direct investment, trade on Africa's economic growth. *International Journal of Innovation and Economics Development*, 3 (1), 72-85.
- Gandolfo, G. (2014). *International trade theory and policy*. Italia: Springer.
- Ghasemi, A., Zahediasl, S. (2012). Normality tests for statistical analysis: a guide for non-statisticians. *International Journal Endocrinol Metab*.10(2), 486-489. DOI: 10.5812/ijem.3505.
- Gouranga, G. D and Kyunggi, D. (2012). *Intra-industry trade and development: revisiting theory, measurement and new evidences*. Retrieved from https://mpra.ub.uni-muenchen.de/37260/1/MPRA_paper_37260.pdf
- Hadi, N. U., Abdullah, N. and Sentosa, I. (2016). Making Sense of Mediating Analysis: A Marketing Perspective. *Review of International Integrative Business & Economics Research*, 5(2), 62-76.
- Halizam, M. A, Ridzuan, A. R., Shaar, M. S., Rahman, N. H. A., and Razak, M. I. (2021). Revisiting the impact of foreign direct investment on Malaysia economic growth. *International Journal of Academic Research in Business and Social Science*, 11(5), 814-826.

Impact of Exports and Foreign Direct Investment.....

- Jan, H., Evžen, K., Mathilde, M. (2010). *Direct and indirect effects of FDI in emerging European markets: a survey and meta-analysis*. Retrieved 19.11.2020 from <https://halshs.archives-ouvertes.fr/halshs-00469544/document> .
- Julio, L. G. (2005). *Comparative advantage, economic growth and free trade*. Retrieved from <http://www.scielo.br/pdf/rec/v9n2/v9n02a04.pdf>
- Keho, Y. (2017). The impact of trade openness on economic growth: the case of Côte d'Ivoire, *Cogent Economics & Finance*, ISSN 2332-2039, Taylor & Francis, Abingdon, 5 (1), 1-14. <http://dx.doi.org/10.1080/23322039.2017.1332820>.
- Khun, S. (2018). The Impact of foreign direct investment on the economic growth in Cambodia: empirical evidence. *International Journal of Innovation and Economic Development*, 4(5), 31-38.
- Kimberly, A. (2020). Comparative advantage theory and examples. Retrieved from <https://www.thebalance.com/comparative-advantage-3305915>
- Kowalski, P. (2011). Comparative advantage and trade performance: policy implications. *OECD Trade Policy Papers*, 121, OECD Publishing. <http://dx.doi.org/10.1787/5kg3vwb8gohl-en>
- Lawrence, A. A., Emmanuel, K. M. & Eric, A. B. (2019). Trade openness, FDI and economic growth in sub-Saharan Africa: do institutions matter? *Transnational Corporations Review*, 11(1), 65-79, DOI: 10.1080/19186444.2019.1578156.
- Mahembe, E. and Odhiambo, N. M. (2014). Foreign direct investment and economic growth: a theoretical framework. *Journal of Governance and Regulation*, 3(2), 63-70.
- Mamingi, N. and Martin, K. (2018). Foreign direct investment and growth in developing countries: evidence from the countries of the Organization of Eastern Caribbean States. *CEPAL Review*, 124, Retrieved 20.11.2020 from <https://repositorio.cepal.org/handle/11362/43952>
- Mona, H. (2015). Does foreign direct investment generate economic growth in Sub-Saharan Africa? *Thesis*. Södertörn University | Institution of Social sciences
- Mukhtarov, S., Alalawneh, M. M., Ibadov, E., & Huseynli, A. (2019). The impact of foreign direct investment on exports in Jordan: An empirical analysis. *Journal of International Studies*, 12(3), 38-47. doi:10.14254/2071-8330.2019/12-3/4
- Mulugeta, G. D. (2017). *International trade and its trends*. Retrieved from https://www.researchgate.net/publication/312212506_International_trade_theories_and_its_trends
- Norimah, B. R., Dayang, A. A. M. & Emilda, H. (2016). The Effect of Foreign Direct Investment, Exports and Employment on Economic Growth Model. *International Journal of Academic Research in Business and Social Sciences*, 6(11), 361-376.
- Pardo, A. and Román, M. (2013). Reflections on the Baron and Kenny model of statistical mediation. *Anales de psicología* 29 (2), 614-623. Retrieved <https://www.redalyc.org/pdf/167/16726244036.pdf>

- Rakhmatullayeva, D., Kuliyeu, I., Beisenbaiyev, Z., and Tabeyev, T. (2020). Assessment of the influence of FDI on the economic growth of the host country: evidence from Kazakhstan. *E3S Web of Conferences* 159, 06007 (2020). <https://doi.org/10.1051/e3sconf/202015906007>. Retrieved 20.11.2020 from <https://www.diva-portal.org/smash/get/diva2:826463/FULLTEXT01.pdf>
- Saleh, S. Sokvibol, K. and Lu, Q. (2019). The gravity model of trade: a theoretical perspective. *Review of innovation and competitiveness* 5(1).
- Satya, D. G. (2015). Comparative advantage and competitive advantage: an economics perspective and a synthesis. *Athens Journal of Business and Economics*,1 (1), 9-22.
- Schober, P., Boer, C. and Schwarte, L. A. (2018). Correlation coefficients: appropriate use and interpretation. *Special Article*,126(5).
- Selimi, N., Reçi, K., and Sadiku, L. (2016). The impact of foreign direct investment on the export performance: empirical evidence for Western Balkan Countries. *ILIRIA International Review*,6(1), 57-66.
- Sudha, B. (2013). Foreign direct investment. *International journal of scientific research*,2(4), 175-177.
- Sultan, Z. A. (2013). A causal relationship between FDI inflows and export: the case of India. *Journal of Economics and Sustainable Development*, 4(2).
- Tamás, K. Fischer, M. M. (2014). The gravity model for international trade: specification and estimation issues in the prevalence of zero flows. Retrieved from https://www.researchgate.net/publication/314377439_The_gravity_model_for_international_trade_Specification_and_estimation_issues
- Tingley, D., Yamamoto, T., Hirose, K., Keele, L. and Imai, K. (2014). Mediation: R Package for causal mediation analysis. *Journal of Statistical Software* 59 (5), 1-38.
- Topi, T. (2011). *Gross domestic product as a modern-day economic indicator*. Retrieved from <https://core.ac.uk/download/pdf/38047645.pdf>
- Tsatsaridis, T. (2017). *The impact of foreign direct investments on economic growth in Sub-Saharan Africa*. Retrieved 20.11.2020 from <https://www.semanticscholar.org/paper/The-impact-of-foreign-direct-investments-on-growth-Tsatsaridis/5b886659dfb0b6c59b348d3def41d8coec3e438b>
- Ukwandu, D. (2015). David Ricardo's theory of comparative advantage and its implication for development in Sub-Saharan Africa. *African Journal of Public Affairs* 8 (3), 17-34.
- UNDP (2020). *Sustainable development goals*. Retrieved 19.11.2020 from <https://www.undp.org/content/undp/en/home/sustainable-development-goals.html>.
- United Nations (2017). *Trade facilitation and paperless trade implementation*. Retrieved https://www.unecce.org/fileadmin/DAM/trade/Publications/ECE_TRADE_438E_UNECERegionalReport2017.pdf

Impact of Exports and Foreign Direct Investment.....

United Nations Conference on Trade and Development (2021). *World Investment Report 2021*. Retrieved on https://unctad.org/system/files/official-document/wir2021_en.pdf

United Nations Conference on Trade and Development. (2016). *Gender-based inequalities and trade performance*. Retrieved from <https://vi.unctad.org/tag/docs/vol1/vol1m3.pdf>

World Bank. (2020). *World Indicator*. Retrieved 23.11.2020 from <https://data.worldbank.org/indicator>